

Near Field Communication-based telemonitoring with integrated ECG recordings

J. Morak¹; H. Kumpusch¹; D. Hayn¹; M. Leitner²; D. Scherr²; F.M. Fruhwald²; G. Schreier¹

¹Safety and Security Department, AIT Austrian Institute of Technology GmbH, Graz;

²Department of Internal Medicine, Division of Cardiology, Medical University of Graz

Keywords

Telemedicine, telehealth; interfaces; usability; mobile phone; near field communication; ECG

Summary

Objective: Telemonitoring of vital signs is an established option in treatment of patients with chronic heart failure (CHF). In order to allow for early detection of atrial fibrillation (AF) which is highly prevalent in the CHF population telemonitoring programs should include electrocardiogram (ECG) signals. It was therefore the aim to extend our current home monitoring system based on mobile phones and Near Field Communication technology (NFC) to enable patients acquiring their ECG signals autonomously in an easy-to-use way.

Methods: We prototypically developed a sensing device for the concurrent acquisition of blood pressure and ECG signals. The design of the device equipped with NFC technology and Bluetooth allowed for intuitive interaction with a mobile phone based patient terminal. This ECG monitoring system was evaluated in the course of a clinical pilot trial to assess the system's technical feasibility, usability and patient's adherence to twice daily usage.

Results: 21 patients (4f, 54 ± 14 years) suffering from CHF were included in the study and were asked to transmit two ECG recordings per day via the telemonitoring system autonomously over a monitoring period of seven days. One patient dropped out from the study. 211 data sets were transmitted over a cumulative monitoring period of 140 days (overall adherence rate 82.2%). 55% and 8% of the transmitted ECG signals were sufficient for ventricular and atrial rhythm assessment, respectively.

Conclusion: Although ECG signal quality has to be improved for better AF detection the developed communication design of joining Bluetooth and NFC technology in our telemonitoring system allows for ambulatory ECG acquisition with high adherence rates and system usability in heart failure patients.

Correspondence to:

Jürgen Morak
Safety & Security Department
AIT Austrian Institute of Technology GmbH
Reininghausstraße 13/1
8020 Graz, Austria
Austria
E-mail: juergen.morak@ait.ac.at

Appl Clin Inf 2011; 2: 481–498

doi:10.4338/ACI-2010-12-RA-0078

received: January 3, 2011

accepted: October 11, 2011

published: November 23, 2011

Citation: J. Morak, H. Kumpusch, D. Hayn, M. Leitner, D. Scherr, F.M. Fruhwald, G. Schreier. Near Field Communication-based telemonitoring with integrated ECG recordings. *Appl Clin Inf* 2011; 2: 481–498
<http://dx.doi.org/10.4338/ACI-2010-12-RA-0078>

Introduction

Motivation for Telemonitoring of Chronic Heart Failure

Chronic Heart Failure (CHF) is one of the major epidemics of the 21st century [1] and is characterized by an increasing prevalence and high hospitalization rates [2]. Due to the complexity of CHF self-management, therapy compliance is often poor, which contributes to the high rate of re-hospitalization and to the overall poor quality of life [2, 3]. Hence, conventional methods (i.e. patient education and training) must be enhanced and new strategies are needed to support patients in CHF self-management. Telemonitoring at home provides advantages not only for the patients themselves but also for the whole healthcare system [1]. The attending physician can carefully watch the overall health status of her/his patients by monitoring various health parameters, namely body weight, blood pressure, heart rate, medication and well-being. This enables the physician to adapt the therapy in due time – avoiding re-admissions to the hospital, emergency cases and extraordinary treatment costs [4].

State of the art

In the last couple of years, several clinical trials have demonstrated the benefits of telemonitoring in the management of CHF. A systematic review done by Inglis et al. state that telemonitoring and structured telephone support interventions are beneficial for the day-to-day management of patients with CHF and may play a significant role in the 'standard' management of CHF [5]. Louis et al. conclude that telemonitoring might play an important role as part of a strategy for effective CHF management [6]. However, up to now the ideal setting in matters of collaborative treatment, monitoring parameters and technical tools [7, 8] has not been found.

The randomized, controlled MOBITEL study [4] revealed significant improvements of CHF patient outcomes. Patients who were randomized to the telemonitoring group were equipped with a common digital blood pressure monitor, body weight scales, and a mobile phone (Nokia 3510, Nokia, Espoo, Finland) running a wireless application (WAP) browser. Each patient was individually trained in using the phone's WAP browser to connect to a telemonitoring service and to perform the following tasks on a daily basis:

- login with username and password
- enter self-assessed blood pressure and body weight data
- enter dosage of taken heart failure medication
- indicate well-being by selecting one out of five options

All steps had to be performed manually using the mobile phone keypad. Based on the results and lessons learned during the MOBITEL study we have developed a novel system for CHF telemonitoring, which is currently in use at the hospital of the Elisabethinen in Linz, Austria and has previously been described [9].

Briefly, the system is again based on mobile phones. Instead of manual data input via keypad Near Field Communication (NFC) is used to acquire all data automatically. NFC is a short range (less than ten centimeters) wireless communication technology that evolved from and is compatible to Radio Frequency Identification (RFID) tags and contactless smartcards. It has been previously shown that NFC has the potential to become the preferred technology for future telemonitoring scenarios [10]. It enables patients to acquire data in an intuitive way just by touching measurement devices with the mobile phone without the need of manually entering data via the mobile phone's keypad. The NFC enabled mobile phone hosts a dedicated software application based on Java 2 Micro Edition (J2ME). Instead of launching the application manually and typing the login-data the patient touches a personal ID card which is based on contactless smartcard technology with the mobile phone. This action automatically launches the application, authenticates the patient and grants access to the secured part of the application where data are collected and synchronized with a remote medical record for the patient being associated with the particular ID card. Data are collected in a predefined workflow (i.e. a strictly defined sequence of steps for acquisition of blood pressure, body weight, medication intake, and well-being). Acquisition of these data is performed by touching the respective measure-

ment device. For this reason a blood pressure meter and body weight scales have been enabled with NFC technology. After reading the data from the devices, questions about medication intake and well-being are presented on the phone's display. To respond to those questions the patient touches specific icons on an icon table equipped with RFID tags. With this new NFC-based patient equipment we were able to overcome usability issues of manual data entry as experienced with the methodology used in the MOBITELE study.

However, due to its very short operating distance and its limited data rate (up to 424 kBit/s), NFC is intended to transmit single rather low data volumes, e.g. blood pressure values, but not for the transmission of relatively large data sets such as digital ECG recordings. On the other hand, in a number of instances, the acquisition of an ECG would be of high value for the diagnosis, management, and prognostic evaluation of patients with CHF in clinical practice. Among others, this may facilitate diagnosis of myocardial ischemia and infarction, atrial fibrillation, left ventricular hypertrophy/dilatation, left bundle branch block and intra-ventricular conduction delays, left atrial abnormality, and QT-interval prolongation [11].

Various mobile telemonitoring systems already provide the acquisition of ECG signals [12–15]. All of these systems use mobile phones for wide area network connectivity and Bluetooth communication between the ECG recorder and the mobile phone. However, none of these systems has been evaluated in the course of a clinical study with respect to usability for the given group of patients. Most of the systems require the application of adhesive electrodes to the chest in order to record an ECG. The quality of the ECG strongly depends on the ability of the patients to apply the electrodes correctly which may pose a problem for daily usage in a telemonitoring scenario. Furthermore the transmission of ECG data between the recorder and the mobile phone via Bluetooth requires manual pairing of the devices. The pairing process is quite complex and may overstrain especially elderly people. Up to now, commercially available solutions don't support data acquisition via NFC. Therefore none of the existing solutions for the acquisition of ECG data in a telemonitoring scenario could be integrated into our existing system.

Objectives

The objectives of the present work were to:

1. Extend the existing CHF telemonitoring system to team the functionality and the usability of the NFC-based system introduced in [9] with the acquisition of ECG data.
2. Evaluate the extended CHF telemonitoring system within a clinical trial concerning
 - usability,
 - patient compliance, and
 - feasibility for early detection of AF in CHF telemonitoring

in a representative patient group.

Methods

ECG enabled patient equipment

The existing CHF telemonitoring system based on NFC and mobile phones was taken as a basis. In order to stay with the intuitive, touch-based data acquisition concept but to include the acquisition of ECG signals with real time transmission from the ECG sensor to the mobile phone major parts of the system had to be redesigned. Additionally, ECG recording features should be added without adding a new device or another step to the acquisition workflow. Thus, we decided to develop an integrated solution to concurrently acquire blood pressure and a single channel ECG signal. For this purpose the following three actions had been taken:

- combination of an ECG recorder with a digital blood pressure monitor
- development of a communication design to easily link the sensing device to a mobile phone
- adaptation of the software application on the mobile phone

1. Digital blood pressure monitor with integrated ECG recorder (sensing device)

A commercial digital blood pressure monitor (UA-767, A&D, Tokyo, Japan) was modified by integrating a prototyped single channel ECG recorder. Three metallic dry electrodes (one channel plus reference electrode) were mounted on the meter's rear side (► Fig. 1) to facilitate skin contact for recording the ECG while performing a blood pressure measurement. This particular placement of the electrodes was chosen so as to allow for two ways of recording, either by touching the electrodes with the fingertips of both hands or by pressing the whole device to the naked chest. The electrodes were connected to a printed circuit board integrated into the meters enclosure. This printed circuit board contained the following components necessary to amplify and digitize the ECG signal:

- instrumentation amplifier (AD620, Analog Devices, Norwood, Massachusetts, USA) to pre-amplify ($G=7$) the ECG signal
- second order sallen-key band pass to filter (0.2–125 Hz) and amplify ($G=142$) the ECG signal
- reference signal circuit to reduce common mode interference
- microcontroller (MSP430, Texas Instruments, Dallas, Texas, USA) to digitize the signal (8 bit resolution at 250 Hz sampling rate)
- Additionally, the printed circuit board was linked to the mainboard of the blood pressure monitor to manage synchronization with the blood pressure recording process. By this modification, the firmware application running on the microcontroller was able to trigger the blood pressure measurement process and to automatically receive the data (systolic and diastolic blood pressure and heart rate) after the measurement was finished.

2. Communication/interaction design

Besides interacting with the blood pressure meter and sampling the amplified ECG signal the integrated microcontroller also acted as the central point for communication (► Fig. 2) to the mobile phone with NFC and Bluetooth capabilities (Nokia 6212 Classic, Nokia, Espoo, Finland). Therefore, the microcontroller was connected to a Bluetooth module (BNC4, Amber Wireless, Cologne, Germany) which was also integrated into the device's enclosure. This Bluetooth module operated the Serial Port Profile (SPP) in transparent mode and was able to be found and selected as slave device by another Bluetooth device operating as master (in this case the mobile phone).

An RFID tag was attached to the enclosure which kept all data required to establish a connection to the Bluetooth module (MAC address and service name). Additionally, a field detector circuit was placed underneath the RFID tag and connected to the microcontroller. This way, the following two independent processes could be started simply by touching the sensing device with the NFC enabled mobile phone:

- The field detector detected the mobile phone's NFC field and caused the microcontroller to activate the Bluetooth module.
- The mobile phone read out the connection information from the RFID tag to establish a Bluetooth connection.

► Table 1 provides an overview of the communication flow between mobile phone and the developed communication platform.

3. Adaption of mobile software application

The existing J2ME software application for monitoring heart failure patients (HF APP) running on an NFC-enabled mobile phone as described in [9] was adapted to manage the new data acquisition process including ECG recording. In this modified version the workflow based user interface guided the patient through the step-by-step data acquisition procedure by giving acoustical instructions. In addition to that instructions have also been shown visually as text and image on the screen. The first step of the data acquisition procedure – after authenticating via the ID card – was the concurrent acquisition of blood pressure and ECG initiated by touching the device with the mobile phone as described in ► table 2.

Before touching the device the patient was instructed to put on the cuff. Right after touching the device the HF APP asks to get into contact with the electrodes with the fingertips of both hands (for

this, the user has to put down the mobile phone). After a delay of seven seconds the blood pressure measurement and the ECG recording started automatically. The ECG signal was streamed via Bluetooth link to the mobile phone (in real time) to be analyzed by the HF APP. In addition to QRS detection a signal quality level was calculated. This level was based on the estimated signal-to-noise ratio (minimum QRS amplitude of all QRS complexes divided by the maximum amplitude of non-QRS-signal portions) as well as the amplitudes of detected QRS complexes and the regularity of the detected QRS complexes. The application displayed the live streamed ECG signal, marked the detected QRS complexes with vertical lines, and visualized the current quality level (0 – 100%) – giving the patient real-time feedback to take care of touching the electrodes properly (see ► Fig. 4). ECG streaming was stopped as soon as the blood pressure measurement was completed. After receiving the blood pressure data the HF APP terminated the Bluetooth connection. Finally, all other data were acquired in the usual way by means of NFC transmissions from devices (body weight scales) and RFID tags (icon table) as reported in [9].

The HF APP was linked to a remote monitoring center via an Universal Mobile Telecommunications System (UMTS) based data service. After each data acquisition procedure data were sent to the monitoring center automatically and stored in the database. A dedicated Web portal was developed that allowed authorized user to access the data via Internet browser. After a secure login procedure study physicians were able to:

- register new study patients
- enter medical history data
- assign study equipment (mobile phone, ID card, sensing device, and body weight scales)
- define target parameters and medication to be monitored
- view transmitted data in lists and trend graphs (blood pressure, body weight, well-being, medication intake)
- view ECG signals by means of a dedicated ECG viewer (► Fig. 3)

Clinical Evaluation

The developed sensing device and the modified HF APP were evaluated in the course of a clinical trial that was conducted at the Medical University of Graz. The study was approved by the corresponding ethics committee (21–283 ex 09/10), and all patients signed informed consent. Patient recruitment was managed by study physicians at the Division of Cardiology. Male or female patients with an age of 18–75 years were considered for the study. Inclusion criteria were the ability to handle the entire telemonitoring equipment (i.e. motor skills, ability to see, comprehension of voice instructions) and sinus rhythm at inclusion examination. Exclusion criteria were scheduled revascularization or surgery of vitium cordis within the following seven days, acute myocarditis, planed or passed cardiac transplantation, amblyopia, or all kind of tremors.

After registration including baseline examination (medical history and ECG recording) by the study physician, patients received the following telemonitoring equipment:

- patient ID card represented by a contact less Smartcard (Mifare Classic 1K, NXP Semiconductors, Eindhoven, Netherlands)
- NFC-enabled mobile phone (Nokia 6212classic) with inserted USIM card and preinstalled new HF APP (► Fig. 4)
- sensing device (instead of existing NFC-enabled blood pressure meter)
- body weight scales (UC-321, A&D, Tokyo, Japan) with NFC interface
- icon table equipped with RFID tags to answer questions about well-being (good, medium, bad) and medication intake
- modified step-by-step user manual

Each patient was individually trained in handling the equipment. After a demonstration by a technically skilled person patients performed one assisted data acquisition themselves. Patients were instructed in how they could influence the ECG recording quality (as visualized on the mobile phone) by changing muscle tonus and electrode contact.

Thereafter, patients were asked to utilize the system twice a day with the following two slightly different usage scenarios:

1. in the evening the electrodes were touched with the fingertips
2. in the morning the sensing device was applied to the chest in a way that the three electrodes contacted the naked skin right above the episternum

The entire workflow is outlined in ► table 2.

Patients were asked to use the equipment over a period of seven days to acquire and send their vital parameters (13 transmissions in total). Although the physicians had permanent access to the Web system and thus could assess the data on a daily basis, medical intervention based on the acquired study data during the monitoring period was not intended. During the study, the patients were able to contact a technical helpdesk or the study physicians in case of problems or questions.

At the end of the seven day observation period, the patients returned the system and attended the final examination where an ECG (12-lead) was acquired using a clinical ECG recorder. To assess individual patient satisfaction, the patients were asked to fill-in a standardized usability questionnaire [16].

Data Analysis

Primary outcome measures were the technical feasibility of the developed sensing device, patient adherence, general user acceptance, and usability. Frequencies of data acquisitions as well as basic statistics were calculated by standard statistical methods using Matlab (The MathWorks, Natick, Massachusetts, USA). Overall patient adherence was assessed by calculating the quotient of the total number of autonomously performed data acquisitions by the cumulative monitoring period. General user acceptance and usability were assessed by analyzing all individual questionnaires.

All ECG signals were reviewed independently by three experts and classified into one of the three possible categories related to the signal's quality:

- low: no clinical usefulness
- medium: sufficient for ventricular rhythm assessment
- high: sufficient for both ventricular and atrial rhythm assessment

Two of the experts were trained cardiologists (FMF and DS) while the third was an expert in biosignal processing (DH) with focus on ECG analysis. In an overall analysis of all transmitted ECG signals we expected that more than 50% would have at least "medium" signal quality. In a patient specific analysis the expectation was that at least 75% of all patients would be able to provide more than one third of self-acquired ECG signals with a signal quality rated higher than "low".

Results

Patient characteristics and monitoring results are summarized in ► table 3. Over a period of ten weeks a total of 21 patients (four females) suffering from CHF were enrolled to the clinical trial. Mean age was 54.1 years (\pm 14.7 years). Median CHF severity of all patients was given by NYHA II. Nine patients suffered from hypertension, eight had known arrhythmia, and six were diagnosed with coronary artery disease or myocardial infarction. Three patients had already suffered from stroke and two patients suffered from diabetes mellitus or COPD, respectively.

41 data sets were recorded at the hospital while the patients were trained. A total of 211 data sets were acquired at the patients' homes and transmitted to the monitoring center by the patients autonomously. The only drop out was a never beginner (female). Two patients transmitted only one single data set due to technical problems (weak battery condition and broken body weight scales). All active patients (N = 20) had a cumulative monitoring period of 140 days. The overall adherence was 82.2% at an expected rate of 13 data sets per patient. The subgroup of 18 patients without technical problems showed a patient adherence rate of 89.3%.

All transmitted monitoring data sets included 211 ECG signals with a mean duration of 40.2 \pm 17.9 seconds, 211 body weight values, 211 indicators for the patients' wellbeing (161 x good, 46 x medium and 4 x bad), and 198 valid blood pressure values (in 13 cases blood pressure measurement was not successful). Depending on the patients' therapy, between one and four drugs were to be docu-

mented by the patients, leading to a final number of 673 data sets about heart failure medication intake for all active patients.

A total of 131 out of all 211 ECG signals were rated with full concordance of all three experts. In 78 cases two experts rated the signals to be of the same category. In those 78 cases the third rating differed 76 times by one category and twice by two categories. Two cases occurred where all three experts rated totally discordant. The distribution of concordance in rating the 211 acquired ECG signals is shown in ► figure 5. The final ratings of those signals are given in ► table 4. It summarizes the ratings of each expert and an overall rating based on a majority vote (► Fig. 6). This average rating of 211 ECG signals revealed that at least 117 ECGs provided “medium” signal quality (55.4% of total). 26 out of these signals (12.3% of total) showed a “high” signal quality. 105 ECG signals were acquired by touching the electrodes with the fingertips while 106 were acquired by applying the electrodes on the naked chest. A U-test to evaluate the differences in signal quality – 43 with “medium” and 16 with “high” versus 48 with “medium” and 10 with “high” respectively (► Fig. 7) – showed no significance ($p = 0.62$).

Detailed analysis of the ECG signals from the subgroup of 18 patients who acquired their data at least once per day over seven days revealed that 16 of the patients were able to provide ECG signals of which at least 33% had been rated as “medium”. Six patients were able to provide ECG signals of which at least 66% had been rated as “medium”. Three patients were able to provide a set of ECG signals of which more than 33% had been rated as “high”.

All 20 active patients returned the completed questionnaires. 19 patients reported that they own a mobile phone while only two of them already used mobile Web services. The detailed results of the questionnaires are summarized in ► table 5. Patients stated that voice commands to guide through the data acquisition process were very helpful. No problems in reading the display were reported. The whole data acquisition procedure including the six steps specified in ► table 2 took 3.9 minutes on average. The individual statements about expenditure of time ranged from one to ten minutes. 17 out of 20 patients rated the idea for this service as very good. All of them would recommend this service to other patients while only ten patients would continue to use this service. Seven of them would be willing to pay for it.

Discussion

An existing and already accepted mobile phone and NFC based CHF telemonitoring method was extended in order to provide ECG recording capabilities. The challenge has been to add this feature without sacrificing the intuitive, touch-based user interface.

The aim of this work was to assess the technical feasibility and usability of the developed sensing device that allows for concurrent acquisition of blood pressure and ECG. The equipment was handed out to patients suffering from CHF and evaluated in the course of a clinical pilot study. The objective (high patient adherence) and subjective (questionnaire) outcomes of the study indicate a high degree of technical feasibility, usability, and patient acceptance.

Technical feasibility

Results revealed that the developed communication design based on a combination of NFC and Bluetooth allows for easy-to-use acquisition and transmission of blood pressure, ECG data, body weight, medication and well-being information. Patients liked the workflow design and the voice instructions which guided them through this workflow very much. High user acceptance was indicated by the fact that almost all patients were willing to use the system as requested.

One participant dropped out due to demurs of his family members concerning the participation in a clinical trial. Two patients reported technical problems when returning the devices. Both were willing to use the system but managed to transmit only a single data set from home. In one case the Bluetooth connection to the sensing device could not be established due to weak battery conditions. The second case was related to a broken body weight scales. Since the data acquisition procedure had to be performed in a strictly defined sequence, the entire procedure failed because the body weight value could not be obtained. None of those three patients contacted the helpdesk or study physician

during their one week observation period. One person contacted the helpdesk one day after inclusion because of the intention to stop using the system. In this case, the patient's concerns of not being able to handle the system could be overcome by telling him that he had already been successful in sending data. Four patients suggested to add immediate feedback, indicating whether the transmission was successful or not and whether the acquired ECG provided sufficient signal quality.

Signal quality

More than 55% of the 211 transmitted data sets were rated at least as "medium" by the experts. In most of the patients (16 of 18) more than one third of the transmitted ECG signals provided sufficient signal quality for ventricular rhythm analysis. However, in three patients only, the signal quality of at least one third of the ECGs was sufficient for atrial rhythm assessment (26 out of 211 signals in total). No significant difference in between the signal quality of ECGs recorded from chest and limb leads were found. Muscle artifacts when touching the electrodes with the fingertips on the one hand, and weak electrode contact to the chest on the other hand seem to have led to similar quality degradations for both methods. The following technical limitations often leading to a noisy ECG signal have been identified:

- low dynamic range and resolution of analog to digital conversion
- weak or fluctuating electrode contact
- drift and movement artifacts
- interference with the RF field of the NFC phone

Since our self-developed ECG recorder had a limited dynamic range due to the low resolution of only 8 bit, while signal drift was very common due to varying electrode contact, the signal quality was limited by design and could easily be optimized by improving these aspects. Additionally, loss of contact might be detected by adding impedance measurements. In this case a sound could alert the user and prompt touching the electrodes properly. The RF interference was caused by the NFC antenna of the mobile phone. The phone's NFC antenna bursts a 13.56 MHz signal every 300 milliseconds to scan the environment for RFID tags. These spikes were visible in the ECG signal if the patient put the mobile phone too close to the sensing device (<30 cm) during ECG measurement and resulted in QRS-like signal morphologies. In the future this will be handled by the HF APP through switching off NFC after reading the pairing information from the RFID tag or by retrospectively reducing these spikes via model based biosignal analysis. This may also help to reduce drift and movement artifacts.

Usability

The combination of NFC and Bluetooth technology provides high usability by establishing communication between the mobile phone and the sensing device simply by bringing them close together. This approach allows to handout and even replace broken devices without the need for pairing or configuration. By means of this plug & play concept all kinds of data (even biosignals with large data volumes like ECGs) can be integrated into the touch-based data acquisition procedure.

The current design of the HF APP provides a workflow based user interface that guides the patient through the strictly defined step-by-step data acquisition process. This approach allowed the usage of audio files for voice commands to tell the user what to do next. This type of self-explaining user instruction was rated very helpful. On the other hand, the strictly defined workflow presented a drawback in the case of the one patient with a broken body weight scales. Three users also reported that it would have been nice to disable voice commands on demand after a run in period. Thereby, the duration needed for the entire data acquisition process could further be reduced.

Conclusion

A concept for the intuitive acquisition of ECG signals in a telemonitoring setting was developed, implemented prototypically and evaluated in the course of a clinical pilot trial. By means of joining Bluetooth with NFC technology, an easy-to-use interface between sensing device and mobile phones was realized. Results indicate high adherence rates and fair system usability in heart failure patients.

Although signal quality was limited by the used ECG recorder component and needs to be improved for routine application the developed communication design allows for a coherent extension of the existing monitoring solution. Hence, the extended system provides for seamless acquisition of all kinds of monitoring data, including biosignals, simply by touching icons and sensor devices with a mobile phone.

Conflict of interest statement

None of the authors have any conflicts of interest associated with the work presented in this manuscript.

Protection of human subjects

The study was performed in compliance with the World Medical Association Declaration of Helsinki on Ethical Principles for Medical Research Involving Human Subject. It was reviewed and approved (21–283 ex 09/10) by the ethics committee of the Medical University of Graz.

Acknowledgements

The project was partly funded by the Styrian government, department 3, science and research; grant number A3–22.E-4/2008–12.



Fig. 1 Picture of modified digital blood pressure monitor UA-767 with three metallic dry electrodes (yellow arrows) to be touched with the fingertips of both hands (right hand: forefinger and middle finger, left hand: forefinger) or applied to the naked chest.

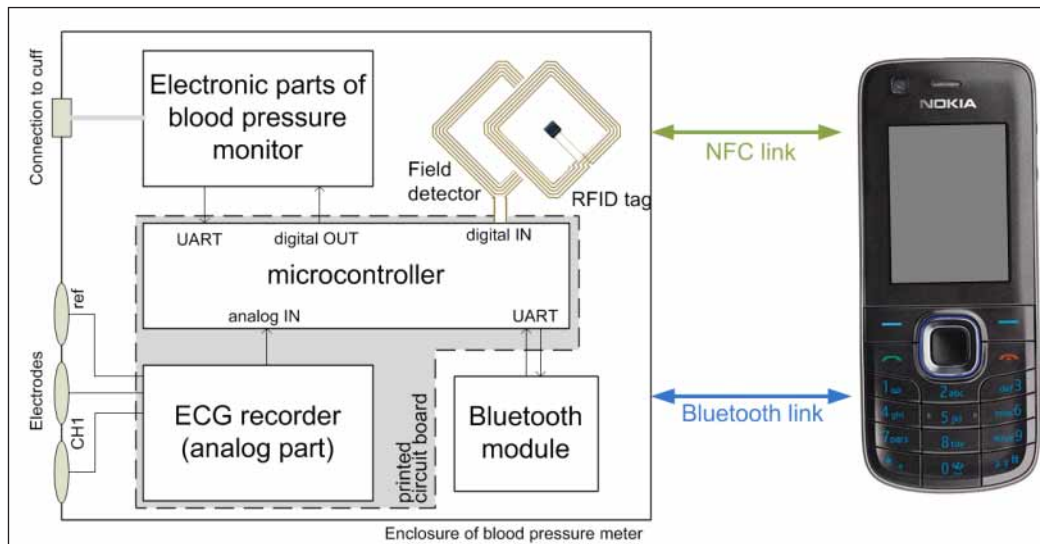

Fig. 2 Overview of the components of the developed sensing device for concurrent acquisition of blood pressure and ECG signals using NFC/Bluetooth communication with a mobile phone.

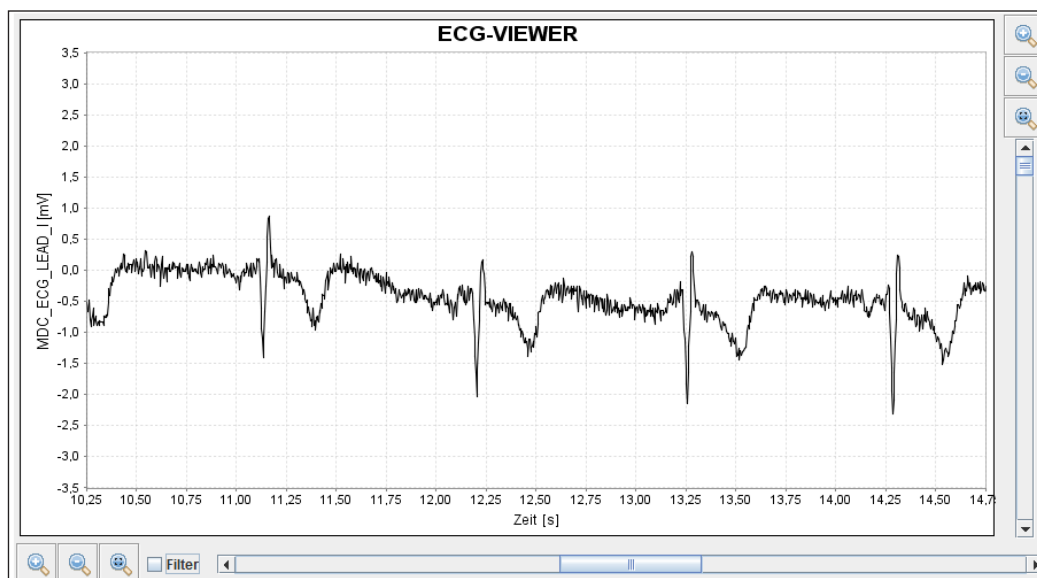

Fig. 3 Screen shot of ECG viewer Java applet which was embedded in the Web portal to view transmitted ECG signals.



Fig. 4 Picture of NFC enabled mobile phone Nokia 6212 classic running the HF APP. Its screen shows the ECG signal streamed by the sensing device and the calculated signal quality level.

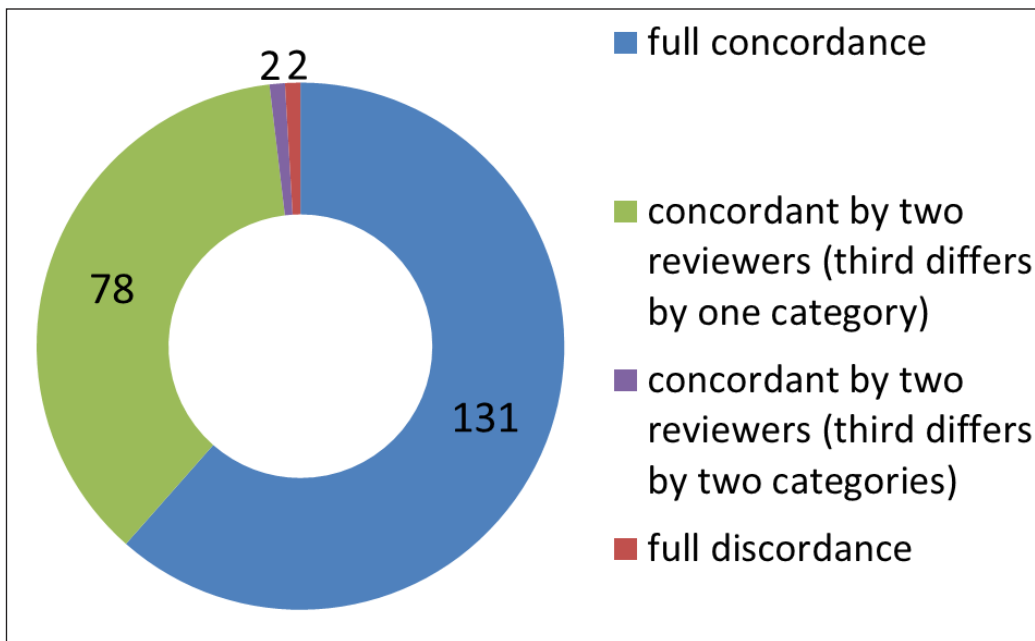

Fig. 5 Concordance of signal quality ratings voted by three independent reviewers. 211 ECG signals were rated to one of three categories. Two cases (red) occurred where no reviewer agreed with another one.

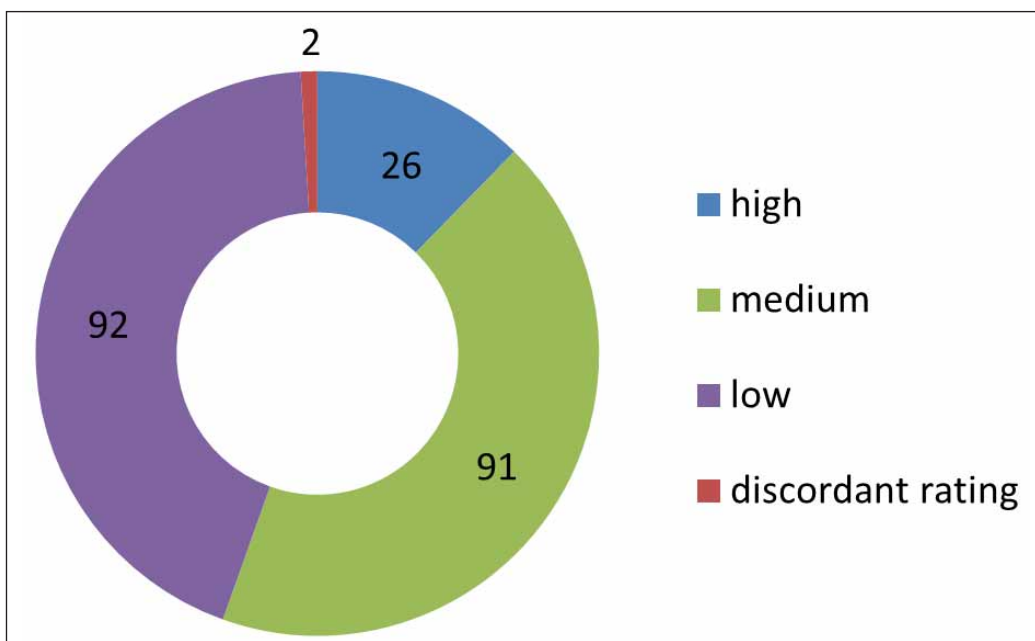

Fig. 6 Overall rating of 211 transmitted ECG signals based on a majority voting.

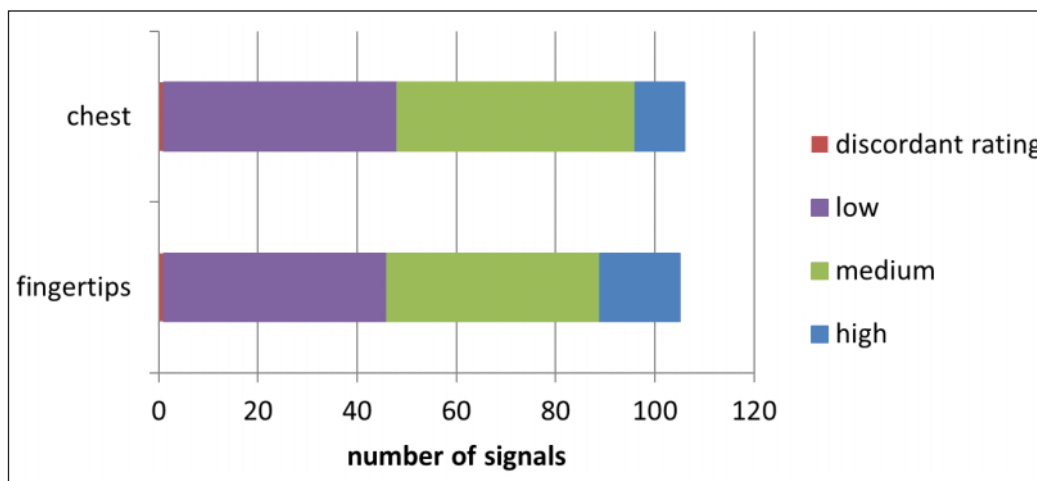

Fig. 7 Comparison of quality level distribution of ECG signals acquired either on the fingertips or the naked chest.

Table 1 Communication flow between mobile phone

Step	Behavior of sensing device	Behavior of mobile phone
1		Mobile phone (with running software application) comes close to the sensing device for reading the RFID tag
2	Microcontroller (μ C) recognizes presence of the mobile phone (via field detector) and enables Bluetooth	
3		Application establishes connection to the Bluetooth module (based on the data stored on the RFID tag)
4	μ C sends a string to the mobile phone (via Bluetooth) to indicate "ready" state	
5		After a dedicated delay the application sends a command to start blood pressure measurement and concurrent ECG recording
6	μ C triggers the inflation of the cuff and starts recording the ECG signal; the signal is streamed to the mobile phone in real time	Application receives ECG data in real time (for analysis and visualization)
7	Once blood pressure measurement has finished, the ECG recording is stopped; blood pressure data are sent to the mobile phone	
8		Application receives blood pressure data and answers with a command to close the communication link
9	μ C disables Bluetooth and waits for the next event triggered by the field detector	

Table 2 Step-by-step data acquisition

Step	Interaction by the patient	Behavior of the mobile application
1	touch ID card	HF APP launch, user authentication next: ask for putting on the cuff and touching sensing device
2	put on cuff touch sensing device	establishes a connection to sensing device next: ask to contact the electrodes
3	contact electrodes with both hands (mobile phone has to be put down) or apply to naked chest	delay of 7 seconds \rightarrow triggers sensing device to perform measurement \rightarrow displays ECG signal and quality level while measurement runs next: ask for body weight
4	step on body weight scales and touch NFC interface	read body weight next: ask for CHF medication
5	touch one of four icons to confirm intake of CHF drugs (up to 4 times)	read the tag data of the touched icon (up to 4 times) next: ask for well-being
6	touch one of three smiley icons to indicate current well-being	read the tag data of the touched icon, upload all data and close application

Table 3 Patient characteristics and monitoring results

Parameter	Total	Mean	SD
Patients (female) [n]	21 (4)		
Age [years]		54.1	14.7
Patients in NYHA class (I / II / III / IV) [n]	9 / 7 / 5 / 0		
Dropouts (female) [n]	1 (1)		
Patients with at least one transmission per day [n]	18		
monitoring period [days]	140		
Transmissions [n]	211	10.6	3.8
Adherence rate [%]	82.2		
Transmissions of subgroup with 18 patients [n]	209	11.6	2.1
● Adherence rate [%]	89.3		
Received data items [n]	1501		
● ECG signals [n]	211	10.6	3.8
● Blood pressure [n]	198	9.9	3.8
● Body weight [n]	211	10.6	3.8
● Well-being			
– Good [n]	161	8.1	4.1
– Medium [n]	46	2.3	3.2
– Bad [n]	4	0.2	0.5
● Medication [n]	673	33.7	15.3

Table 4 Summarized rating of all ECG signals. Signals were rated independently by three experts. Overall signal quality rating was calculated by using two out of three concordant ratings. Two signals were rated completely discordant.

Reviewer	Rating of ECG signals to categories of signal quality			
	Low	medium	high	discordant rating
Expert 1	91	94	26	
Expert 2	82	100	29	
Expert 3	106	82	23	
Overall rating	92	91	26	2

Table 5 Summary of analyzed patient questionnaires (translated from German)

Nr.	Question	Rating	
Common questions			
Q1	Do you own a mobile phone?	yes: 19	no: 1
Q2	Have you ever used mobile Web services?	yes: 2	no: 18
Q3	How much money do you spend for your health per month? 5–10 € / 10–20 € / 20–30 € / 30–40 € / >40 € / no comment	1 / 3 / 5 / 3 / 7 / 1	
Question about system performance [1–7, the higher the better]		SD	SD
Q4	Confusing/clearly aligned	5,70	1,59
Q5	Easy to learn/hard to learn	6,45	0,94
Q6	Unintelligible/ intelligible	6,65	0,59
Q7	Conventional/novel	6,15	1,35
Q8	Fanciless/innovative	6,25	0,97
Q9	Conservative/innovative	6,21	1,13
Q10	Conventional/inventive	6,30	0,73
Q11	Drowsy/activating	6,05	1,00
Q12	Boring/exciting	5,95	1,00
Q13	Inferior/valuable	6,40	0,75
Q14	Uninteresting/interesting	6,30	0,98
Q15	Obstructive/supporting	6,30	0,98
Q16	Not according to expectations/according to expectations	6,10	1,02
Q17	Unpredictable/predictable	6,05	1,10
Q18	Unsafe/safe	5,65	1,50
Q19	Inefficient/efficient	5,94	1,16
Q20	Slow/fast	5,85	1,18
Q21	Cluttered/well-arranged	6,11	1,05
Q22	Not pragmatic/pragmatic	5,50	1,50
Specific question regarding the handling of the devices			
Q23	Was the display legible?	yes: 20	no: 0
Q24	Did you understand the voice output?	yes: 20	no: 0
Q25	Was the voice output helpful?	yes: 19	no: 1
Q26	Did you have problems collecting the data with the mobile phone?	yes: 6	no: 14
Q27	Did you have problems acquiring the ECG signals?	yes: 9	no: 11
Q28	Was the signal quality level during acquisition helpful for you?	yes: 18	no: 2
Q29	How long did it take to acquire all data in average? [minutes]	3.9	2.3

Table 5 Continued

Nr.	Question	Rating	
Questions regarding the system's advantage			
Q30	Do you think this service is a good idea in general? [1= very good – 5= very bad]	Mean = 1.2	SD = 0.4
Q31	Would you recommend this service to other patients?	yes: 20	no: 0
Q32	Would you use your own mobile phone for this service (technical capability assumed)?	yes: 20	no: 0
Q33	Would you like to continue to use this service?	yes: 10	no: 10
Q34	Would you use the service even if you had to pay for it?	yes: 7	no: 13
Q35	If yes, how much would you spend on this service?	3 x 10 €, 3 x 20 €, 1 x 30 €	
Q36	Did you inform your colleagues or friends about this service?	yes: 11	no: 9
Q37	Did you discuss this service with your general practitioner? What was his/her impression?	yes: 1 interesting	no: 19
Additional comments			
	Want feedback or reporting after transmission.		
	A reminder would be helpful.		
	Would like to disable voice output after handling was learned.		
	Could not interpret ECG signal quality!		
	The daily control of blood pressure and body weight was helpful to be aware.		

References

1. Dickstein K, Cohen-Solal A, Filippatos G, McMurray JJV, Ponikowski P, Poole-Wilson PA, et al. ESC Guidelines for the diagnosis and treatment of acute and chronic heart failure 2008. *Eur Heart J* 2008; 29(19): 2388–2442.
2. Hunt SA; American College of Cardiology; American Heart Association Task Force on Practice Guidelines. ACC/AHA 2005 guideline update for the diagnosis and management of chronic heart failure in the adult. *J Am Coll Cardiol* 2006; 47(7): 1503–1505.
3. Scherr D, Zweiker R, Kollmann A, Kastner P, Schreier G, Fruhwald FM. Mobile phone-based surveillance of cardiac patients at home. *J Telemed Telecare* 2006; 12(5): 255–261.
4. Scherr D, Kastner P, Kollmann A, Hallas A, Auer J, Krappinger H, et al. Effect of home-based telemonitoring using mobile phone technology on the out-come of heart failure patients after an episode of acute decompensation: randomized controlled trial. *J Med Internet Res* 2009; 11(3): e34.
5. Inglis SC, Clark RA, McAlister FA, Ball J, Lewinter C, Cullington D, et al. Structured telephone support or telemonitoring programmes for patients with chronic heart failure. *Cochrane Database Syst Rev* 2010; (8): CD007228.
6. Louis AA, Turner T, Gretton M, Baksh A, Cleland JGF. A systematic review of telemonitoring for the management of heart failure. *Eur J Heart Fail* 2003; 5(5): 583–590.
7. Chaudhry SI, Mattera JA, Curtis JP, Spertus JA, Herrin J, Lin Z, et al. Telemonitoring in patients with heart failure. *N Engl J Med* 2010; 363(24): 2301–2309.
8. Koehler F, Winkler S, Schieber M, Sechtem U, Stangl K, Böhm M et al. Telemedical Interventional Monitoring in Heart Failure (TIM-HF), a randomized, controlled intervention trial investigating the impact of telemedicine on mortality in ambulatory patients with heart failure: study design. *Eur J Heart Fail* 2010; 12(12): 1354–1362.
9. Kastner P, Morak J, Modre R, Kollmann A, Ebner C, Fruhwald FM, et al. Innovative telemonitoring system for cardiology: from science to routine operation. *Appl Clin Inf* 2010; 1(2): 165–176.
10. Morak J, Kollmann A, Schreier G. Feasibility and usability of a home monitoring concept based on mobile phones and near field communication (NFC) technology. *Stud Health Technol Inform* 2007; 129(Pt 1): 112–116.
11. Madias JE. The resting electrocardiogram in the management of patients with congestive heart failure: established applications and new insights. *Pacing Clin Electrophysiol* 2007; 30(1): 123–128.
12. Jasemian Y, Arendt-Nielsen L. Evaluation of a realtime, remote monitoring telemedicine system using the Bluetooth protocol and a mobile phone network. *J Telemed Telecare* 2005; 11(5): 256–260.
13. Galbiati F, Takizawa K, Holopainen A. Mobile ECG – A new eHealth solution for telecardiology based on eHIT Health Gateway platform. *Proceedings of the Med-e-Tel; 2007 April 1–3; Luxembourg. Luxembourg: Luxexpo; 2007. p. 101–4.*
14. Kailanto H, Hyvarinen E, Hyttinen J. Mobile ECG measurement and analysis system using mobile phone as the base station. *Proceedings of 2nd International Conference on Pervasive Computing Technologies for Healthcare; 2008 Jan 30 – Feb 1; Tampere, Finland. p. 12–14.*
15. Laakko T, Leppanen J, Lahteenmaki J, and Nummiahio A. Multipurpose mobile platform for telemedicine applications. *Proceedings of 2nd International Conference on Pervasive Computing Technologies for Healthcare; 2008 Jan 30 – Feb 1; Tampere, Finland. p. 245–248.*
16. Laugwitz B, Schrepp M, Held T. Konstruktion eines Fragebogens zur Messung der User Experience von Softwareprodukten. In *Mensch & Computer 2006: Mensch und Computer im Strukturwandel*; Munich, Germany. Munich: Oldenburg; 2006. p. 125–134. German.